

EXCEL

Excel Wall Mounted Cabinets – 600 Series



Range of heights – 9u through to 18u

Quick release side panels for easy access

Features

- Available in 4 heights, 9u, 12u, 15u, and 18u
- Available in Black
- Aesthetically pleasing framed safety glass front door
- Quick release doors and side panel
- Adjustable front and rear 19" mounting profiles
- Removable cable entry panel in top and base

Product Overview

The Excel 600 series is a range of 19" 600mm wall mount enclosures designed for installation of both cabling and equipment, and is ideal for use across a range of applications including local area networking (LAN) cabling and hardware, and the housing of security and audio and visual equipment.

Each cabinet is designed with strength, ease of use and aesthetics in mind. Features such as quick release doors and side panels, fully adjustable front and rear profiles and above average access through the either the top or base of the cabinet make the product extremely flexible and easy to install cables and equipment into.

A full range of Excel accessories are available to complete cable or equipment installation from shelving through to ventilation and power distribution units.

Exploded View

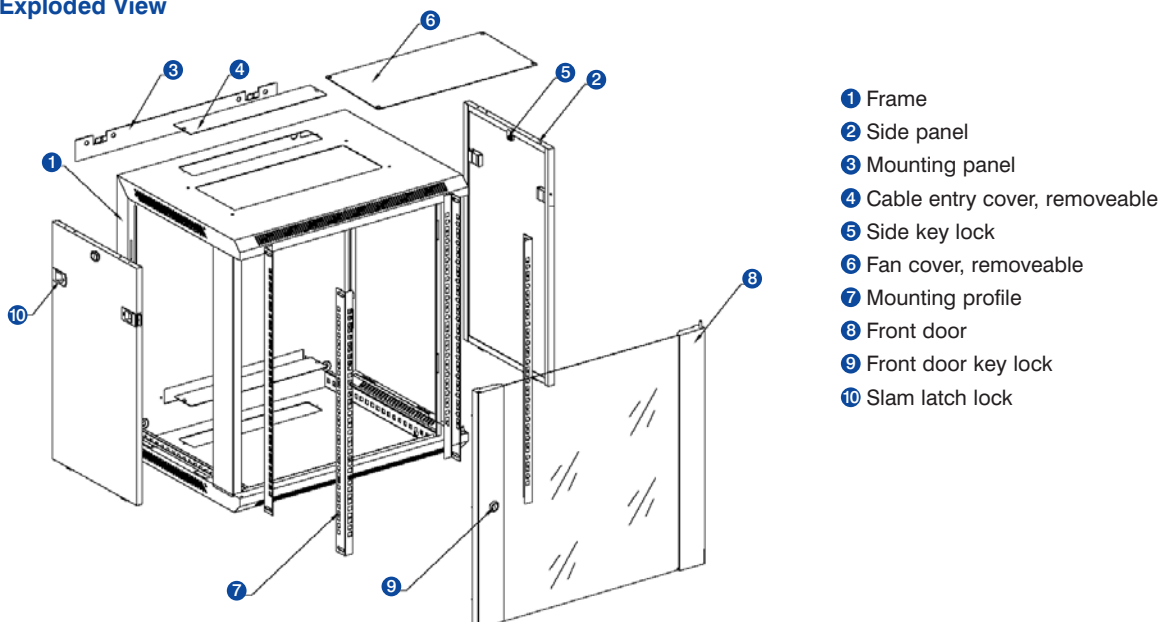

Sectional Views

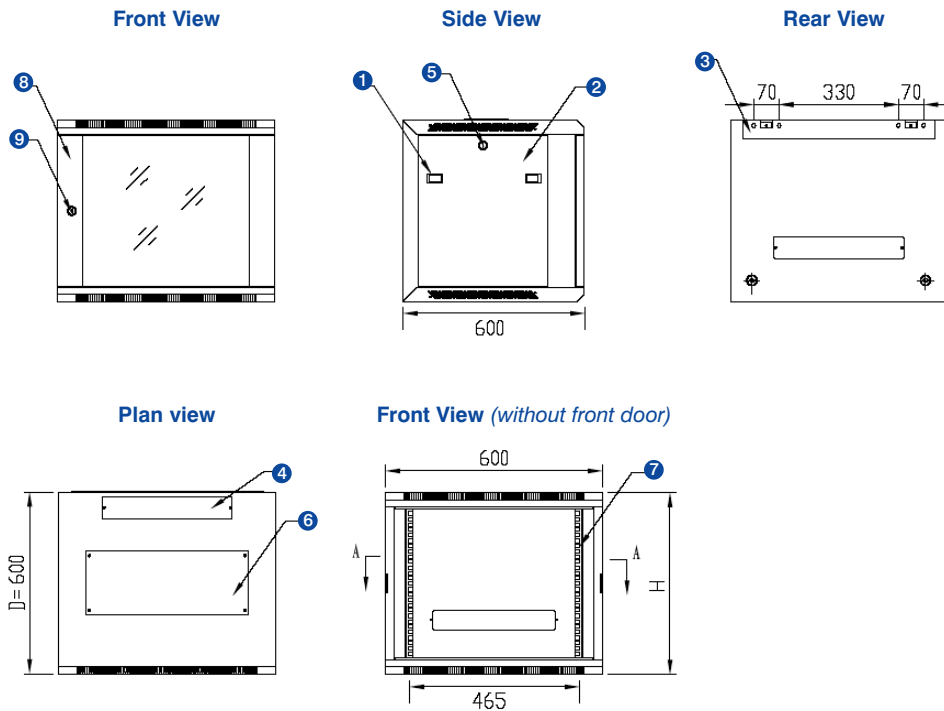

- ① Slam latch lock
- ② Side panel
- ③ Mounting panel
- ④ Cable entry cover, removeable
- ⑤ Side key lock
- ⑥ Fan cover, removeable
- ⑦ Mounting profile
- ⑧ Front door
- ⑨ Front door key lock

All dimensions are shown in mm

Product Specification

Material Thickness

Cabinet Part	
Frame	1.20mm
Top cover and fan entry plate	1.20mm
19" mounting angles	1.50mm
Side panels	1.20mm
Front door frame	1.20mm
Front door glass	5.00mm

Product Standard Compliance

Manufacturing facility	ISO 9001:2000
19" mounting angles	IEC297-1
Overall cabinet dimensions	IEC297-2
Load carrying capacity	60kg
Paint finish, black cabinet	Ral 9004
Paint finish, front door blue trim	Ral 5013
Glass door, safety specification	BS3193:1993
Surface treatment	Fosfat Coating

Product Features



- Aesthetically pleasing design with framed glass front door



- Lockable, quick release side panels, for maximum access into cabinet



- Angled vented roof

Part Number Information

U Size	Width (mm)	Overall Height (mm)	Depth (mm)	Part Number - Black
600 Series				
9u	600	501	600	WB9.6SGB
12u	600	635	600	WB12.6SGB
15u	600	769	600	WB15.6SGB
18u	600	901	600	WB18.6SGB

The Excel series of wall mount cabinets are also available in 390mm & 500mm depths. We also supply a broad range of floor standing cabinets.



Excel is a complete, end-to-end networking solution, offering exceptional performance and support, manufactured to European quality standards and covered by one warranty.

Contact us at sales@excel-networking.com

WWW.EXCEL-NETWORKING.COM